

Svetlana EL509 / EL519 / 6KG6

High Performance Beam Power Tetrode



The Svetlana EL509 is a beam power tetrode intended for use in class A, AB or B audio amplifiers and for class B or C RF amplification. Close manufacturing specification tolerances and improved high voltage processing provides improved reliability and superior performance.

The Svetlana EL509 features: Increased peak cathode emission from new cathode materials; Stable operation from extended processing and aging; Gold-plated grid; Precise grid/screen alignment; Extraheavy glass envelope for ruggedness; Improved vacuum processing; Comprehensive testing before and after aging.

The Svetlana EL509 is manufactured in Russia at the Svetlana factory and is designed to be a direct replacement for any 6KG6 or EL509. The strict manufacturing and quality controls at the Svetlana plant assure functionality and long life.

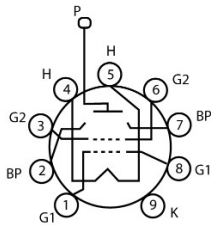
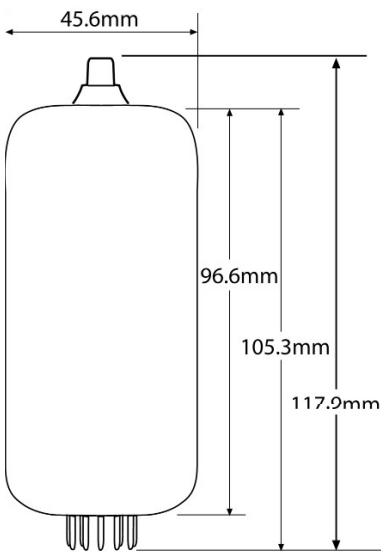

Electrical

Heater	Min	Nom	Max	
Voltage(AC,DC)	5.7	6.3	6.9	V
Current		2.5		A
Transconductance(nominal)			18,000	μ S
Plate resistance(nominal)			8,000	Ω
Interelectrode capacitances(typical):				
Grid to cathode			25	pF
Grid to plate			2.5	pF

Maximum Ratings

DC plate voltage	900	V
DC plate voltage, pulsed	8,000	V
Grid2(screen) DC voltage	300	V
DC cathode current	500	mA
Plate dissipation	35	W
Grid2 DC screen dissipation	7	W

Typical Operation

Audio Amplifier, Class A1 (single tube)

DC plate voltage	500	V
Grid2(screen) DC voltage	280	V
Grid1(control) voltage	-82	V
Peak grid drive	50	VP-P
Zero signal plate current	70	mA
Max signal plate current	100	mA
Effective load resistance	1,650	Ω
Distortion at 1 watt into 8 ohms	0.9	%
Output power at 5% distortion	14	W

